



Hisense | **fire tv**

Quick Setup Guide

Before using the TV, please read this guide carefully
and keep it for future reference.



20141750 B

English

Congratulations on the purchase of your Hisense TV! If you would like to know 'all things Hisense', contact us using the support info: The model and serial number of the TV is located on the back and/or on one side of the TV. We recommend that you record this if you ever need service.

Country	U.S.A	CANADA	MEXICO
Customer Care Center	<ul style="list-style-type: none"> • Phone: 1-888-935-8880 • Hours of Operation: Monday - Friday: 9 AM to 9 PM EST Saturday - Sunday: 9 AM to 6 PM EST • Service Email: Service@hisense-usa.com <p>USA: Hisense USA Corporation 105 Satellite BLVD Suite I, Suwanee, GA 30024</p>	<ul style="list-style-type: none"> • Phone: 1-855-344-7367 • Hours of Operation: Monday - Friday: 8 AM to 8 PM EST Saturday - Sunday: 9 AM to 6 PM EST, Federal holidays excluded • Service Email: canadasupport@hisense.com <p>CANADA: Hisense Canada Co., Ltd 2550 Meadowvale Boulevard, Unit 1 Mississauga, ON, Canada L5N 8C2</p>	<ul style="list-style-type: none"> • Phone: 800-008-8880 • Hours of Operation: Monday - Friday: 9 AM to 9 PM Saturday: 9 AM to 3 PM • Service Email: mxservicio@hisense.com <p>MEXICO IMPORTER: Hisense Mexico S. de R.L. de C.V. Blvd. Miguel de Cervantes Saavedra No 301 Torre Norte Piso 2, Col. Ampliación Granada Miguel Hidalgo, Ciudad de México, C.P. 11520</p>
Hisense Support Page	<p>http://www.hisense-usa.com/support/</p>  <p>For Software issues, contact https://amazon.com/deviceservices/support</p>	<p>http://www.hisense-canada.com/support/</p>  <p>For Software issues, contact https://amazon.com/deviceservices/support</p>	<p>https://hisense.com.mx/support/</p>  <p>For Software issues, contact https://amazon.com/deviceservices/support</p>
Register your TV	<p>http://www.hisense-usa.com/support/register</p> 	<p>http://www.hisense-canada.com/support/productReg.asp</p> 	<p>https://hisense.com.mx/support/register</p> 

Disclaimer

Disclaimer: Subscriptions or other payments may be required to access content through some applications. Some or all of the included or downloaded application services in this Hisense device may not function depending on the Internet connection, local limitations of included applications or other reasons outside of Hisense's control. HISENSE EXPRESSLY DISCLAIMS RESPONSIBILITY FOR ANY APPLICATION SERVICE FROM FUNCTIONING AT ANY TIME, FOR CONTENT IN ANY APPLICATION SERVICE, FOR DISRUPTIONS OF SERVICE, LOCAL OR REGIONAL LIMITATIONS, WARRANTIES OF TITLE, NO INFRINGEMENT, AND FOR IMPLIED WARRANTIES OF MERCHANTABILITY OR FITNESS FOR A PARTICULAR PURPOSE. By purchasing this device, you accept such Disclaimer without any claim on Hisense at any time.

This Quick Setup Guide supports the following models:

**55U7SF / 55U7SFD / 55U70SF / 55U75SF / 55U78SF / 55U75SFB / 55U75SFC /
55U7SFM / 55U75SFM**

What's in the box

Your Hisense TV comes with the following items:

- TV
- Power cord
- Remote control
- 2 base stands
- 1 base cover
- Quick Setup Guide (this document)
- 1 set of AAA batteries
- Important Safety Information and Warranty Card
- 4 screws

NOTE:

The accessories may be different from the list above due to different models, countries/ regions, please refer to the actual accessory bag.

IMPORTANT:

To prevent accidentally discarding items that came with your TV, be sure to **check ALL of the foam** in the carton box.

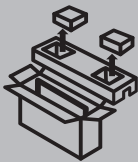

- Please check foam for accessories before discarding.
- Veuillez vérifier la mousse pour qu'il n'y ait pas d'accessoires avant de la jeter.
- Antes de desechar la espuma, asegúrese de retirar todos los accesorios.

Disclaimer: This Quick Setup Guide is intended as a general guideline to help you set up your TV. Images throughout this document are for illustrative purposes only and may differ from the actual product.

Getting started

Step 1. Attach stand or mount

Before you start using your TV, attach your TV stand or mount it on the wall.

CAUTION:

- Disconnect the AC power cord before installing a stand or a wall mount bracket.
- The display on your TV is fragile. Make sure the TV screen is not scratched or damaged by hard objects or from pressure.
- After the installation is completed, make sure the TV is steady on a table or firmly attached to a wall mount, before removing all protective film, if any.

Attach the TV stand

To attach the TV stand to your TV:

1. Carefully place your TV face-down on a soft, flat surface to prevent damage to the TV or scratching to the screen.
2. Take out the 2 base stands and 1 base cover from the upper cushion.
3. Insert the base stands into the bottom slots of the TV and secure stands with the 4 screws in accessory tightly.

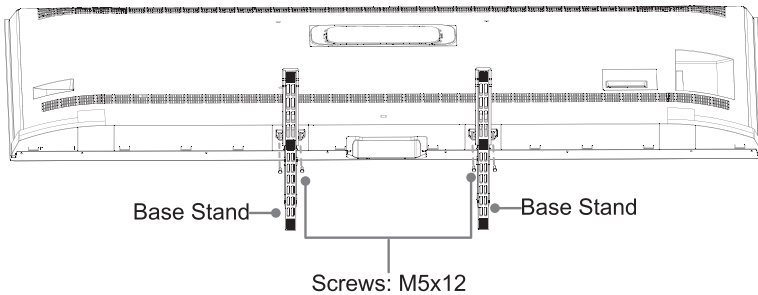

4. Two people set up your TV upright on its stands and move the TV to a flat surface.
 5. Insert the base cover into the 2 base stands from the TV front as the illustration shows.
- ① Put the base cover on the base stands, and push forward from the starting positions.

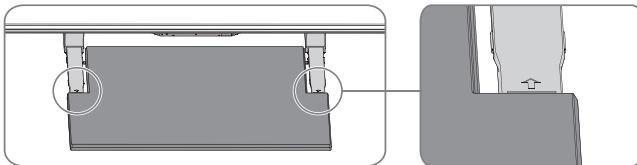

NOTE

- Some models may not have the arrow marks, please refer to the specific product.

- 2 Ensure Part B is under Part A when pushing forward.

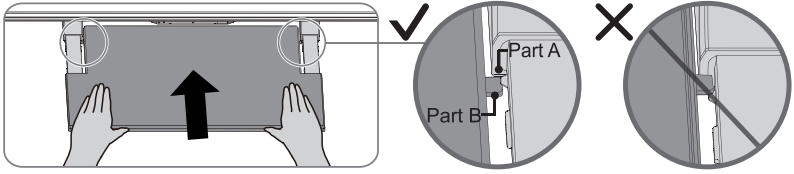

- 3 Apply gentle downward pressure while pushing it forward with two hands. Push until the base cover reaches the stand columns, and make sure there is no gap between them.

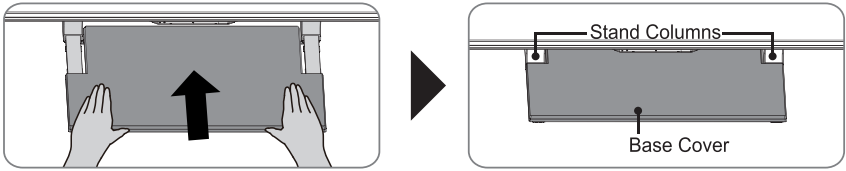

Attach the wall mount bracket (not included)

Before you begin the third-party manufacturer instructions, be sure to do the following things:

1. Place the TV on a clean, safe and cushioned surface.
2. Remove the TV stand if you have already attached it.
3. Place spacers (not included) in the corresponding bracket holes.

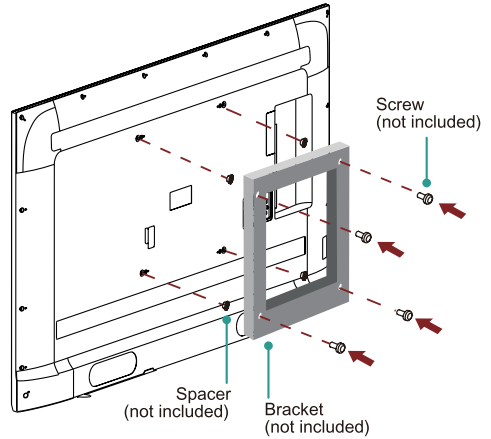

CAUTION:

- Follow instructions provided with the wall mount bracket. If it is not correctly mounted, the TV may fall and cause property damage or personal injury.
- When you attach the mount, be sure to use spacers (provided by the third-party manufacturer) between the TV and the bracket.
- To prevent internal damage to the TV and to ensure it is mounted securely, be sure to use fixing screws (not included) that are 9.5 - 11.5 mm in length when measured from the attaching surface of the rear cover.

9.5 - 11.5 mm

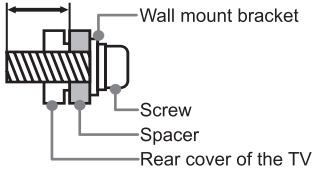

Wall mount hole pattern(mm)	400 × 200
Wall mount screw size	M6
Number of wall mount screw	4

- We do not recommend hanging the TV on a slanted wall, and when wall mounting make sure your television remains parallel to the wall and does not lean forward.

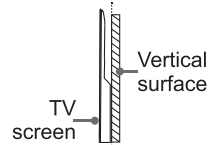

NOTE:

- If installed on a ceiling or slanted wall, or the television installed is not parallel to the wall, the television may fall and result in property damage or severe personal injury.
- If you have additional questions, please contact the wall mount manufacturer or the retailer from which you purchased the TV.
- The diameter and length of the screws differ depending on the wall mount bracket model.

Step 2. Connect devices to your TV

Check to ensure that you have connected the right cables to the right ports securely. Loose connections can affect the quality of the picture image and color.

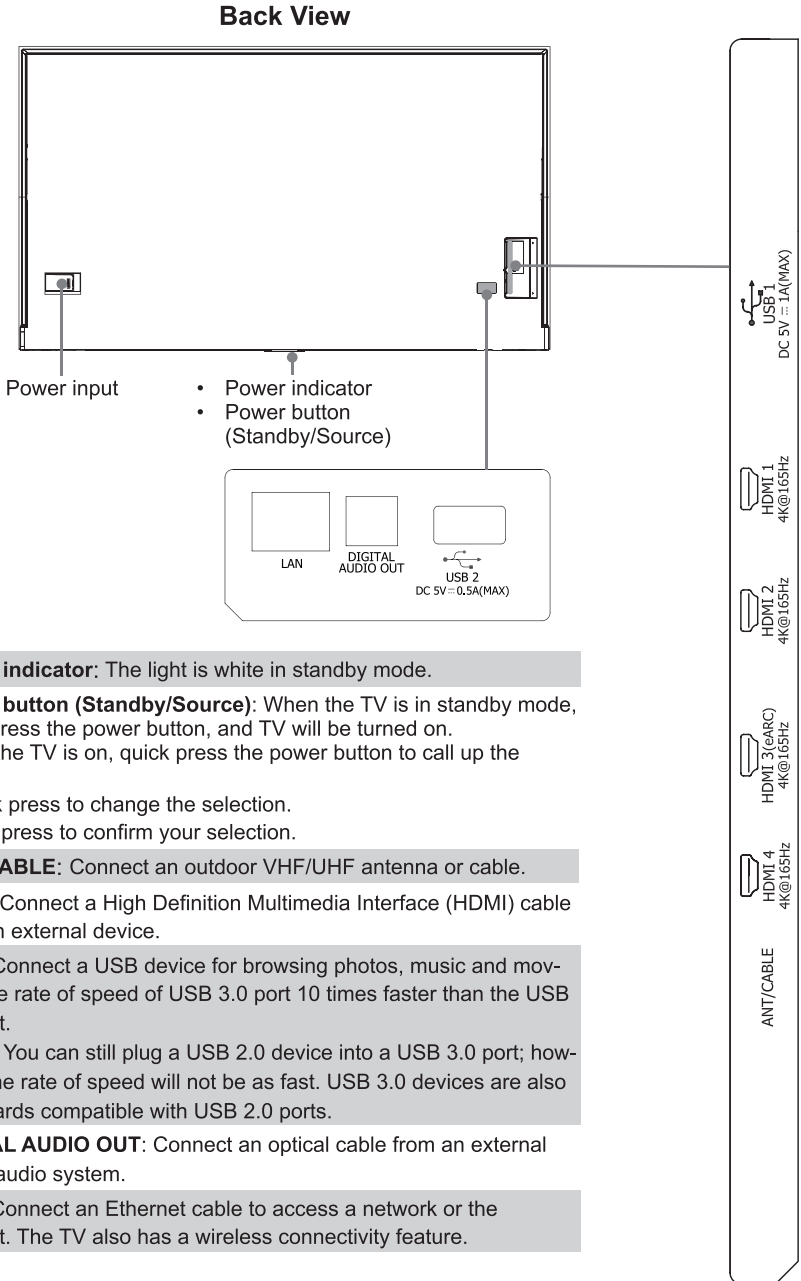

- **Power indicator:** The light is white in standby mode.
- **Power button (Standby/Source):** When the TV is in standby mode, quick press the power button, and TV will be turned on. When the TV is on, quick press the power button to call up the menu:
 - Quick press to change the selection.
 - Long press to confirm your selection.
- **ANT/CABLE:** Connect an outdoor VHF/UHF antenna or cable.
- **HDMI:** Connect a High Definition Multimedia Interface (HDMI) cable from an external device.
- **USB:** Connect a USB device for browsing photos, music and movies. The rate of speed of USB 3.0 port 10 times faster than the USB 2.0 port.
NOTE: You can still plug a USB 2.0 device into a USB 3.0 port; however, the rate of speed will not be as fast. USB 3.0 devices are also backwards compatible with USB 2.0 ports.
- **DIGITAL AUDIO OUT:** Connect an optical cable from an external digital audio system.
- **LAN:** Connect an Ethernet cable to access a network or the Internet. The TV also has a wireless connectivity feature.

Step 3. Get to know controls

Control on the TV

Front view

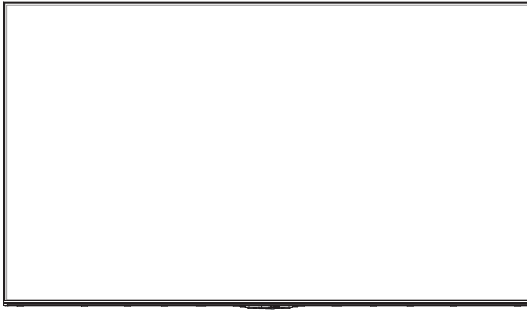

- Remote sensor
- Light sensor
- Microphone
- Voice indicator
- Built-in microphone control button

- **Light sensor:** It enables the TV to automatically adjust the picture settings according to the amount of ambient light in your room. You can enable or disable it in Settings > Intelligent Settings > Automatic Light Sensor.
- **Built-in microphone control button:** It is used for your hands-free voice control. You can quickly switch it off by turning off the built-in microphone control button.

Introduction

Unlock the power of your Hisense with Fire TV built-in with the included Voice Remote with Alexa. Use your voice to watch live TV, search for titles, play music, switch inputs, control compatible smart home devices, and more. Switch inputs and go from watching your favorite TV show to the big game. You can also ask Alexa to check the weather, set timers and reminders, and more. Here are a few things that you can do with your voice on your Hisense Fire TV:

To do this on your Hisense FireTV...	Say this...
<p>Live TV Controls</p> <p>For supported apps that feature live TV access, you can use Alexa to change channels. You can also use Alexa to navigate to the Channel Guide and the Live tab.</p>	<p>“Alexa, go to [channel / network] on [app].”</p> <p>“Alexa, watch [channel / network].”</p> <p>“Alexa, go to Channel Guide.”</p> <p>“Alexa, go to Live.”</p>
<p>Search for movies and TV shows</p> <p>Alexa can find movies and TV shows.</p>	<p>“Alexa, show me new [tv shows / movies].”</p> <p>“Alexa, find [title / genre].”</p>
<p>Alexa Requests</p> <p>See the responses on Hisense with Fire TV when you make an Alexa request</p>	<p>“Alexa, show me the weather.”</p> <p>“Alexa, add x to my shopping list.”</p> <p>“Alexa, play songs by [artist].”</p> <p>“Alexa, show me restaurants nearby.”</p>

Get your remote ready

The following table shows the buttons on your remote control and describes what they are for.

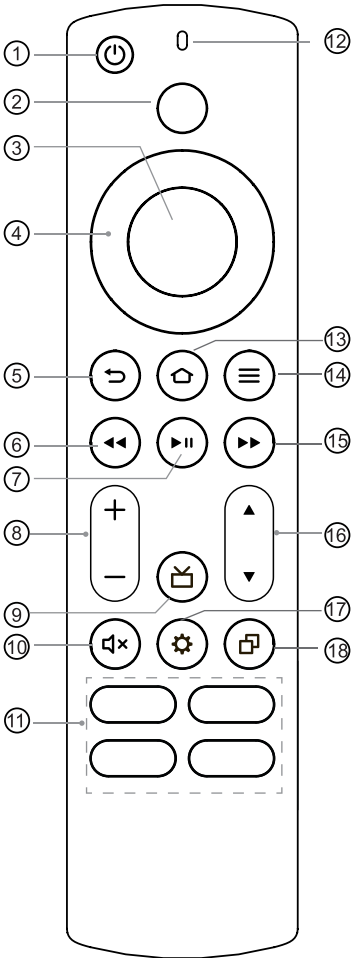

- ① **POWER:** Turn your TV on or off
- ② **🎤 / 🗣️ Voice button:** Holding down the Voice Button to activate the microphone
- ③ **Select:** Confirm a selection or action
- ④ **D-pad** (up/down/left/right navigation buttons)
- ⑤ **Back:** Return to the previous place in the menu or app
- ⑥ **REWIND:** Rewind streaming video
- ⑦ **PLAY/PAUSE:** Pause or resume playback. This button is also used to activate and use the Live TV pause feature
- ⑧ **VOLUME + / VOLUME -:** Increase/decrease the volume
- ⑨ **Guide:** Open the Live TV Channel Guide
- ⑩ **MUTE:** Mute or un-mute the sound
- ⑪ **App buttons:** Quick access buttons to apps
- ⑫ **Microphone:** Receive the voice
- ⑬ **HOME:** Display your TV's Home screen
- ⑭ **MENU:** The button for the Menu
- ⑮ **FAST FORWARD:** Fast forward streaming video
- ⑯ **Channel ▲ / Channel ▼:** Switch channel
- ⑰ **Quick Settings:** Activate quick settings overlay
- ⑱ **Recents:** Open a row of recently watched content so you can easily switch between contents

NOTE:

- The picture is only for reference. Check information according to the actual remote control.

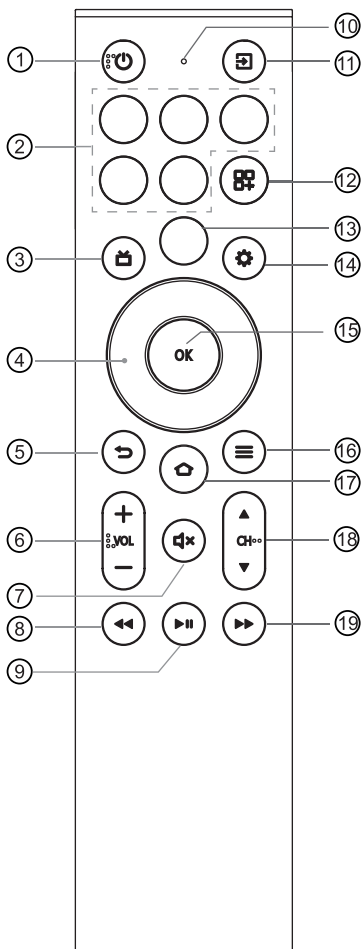

- ① **POWER:** Turn your TV on or off
- ② **App buttons:** Quick access buttons to apps
- ③ **Guide:** Open the Live TV Channel Guide
- ④ **D-pad** (up/down/left/right navigation buttons)
- ⑤ **Back:** Return to the previous place in the menu or app
- ⑥ **VOLUME + / VOLUME -:** Increase/decrease the volume
- ⑦ **MUTE:** Mute or un-mute the sound
- ⑧ **REWIND:** Rewind streaming video
- ⑨ **PLAY/PAUSE:** Pause or resume playback. This button is also used to activate and use the Live TV pause feature
- ⑩ **Microphone:** Receive the voice
- ⑪ **Input:** Change TV input source
- ⑫ **Apps:** Fast access to all applications
- ⑬ **🗣️ / 🗣️ Voice button:** Holding down the Voice Button to activate the microphone
- ⑭ **Quick Settings:** Activate quick settings overlay
- ⑮ **Select:** Confirm a selection or action
- ⑯ **MENU:** The button for the Menu
- ⑰ **HOME:** Display your TV's Home screen
- ⑱ **Channel ▲ / Channel ▼:** Switch channel
- ⑲ **FAST FORWARD:** Fast forward streaming video

NOTE:

- The picture is only for reference. Check information according to the actual remote control.

Insert the batteries

Remove the battery door and insert the two AAA batteries into your Voice Remote with Alexa.

Important information about the remote and batteries

- Discard batteries in a designated disposal area. Do not throw them into a fire.
- Remove old batteries immediately to prevent them from leaking into the battery compartment.
- If you do not intend to use the remote control for a long time, then remove the batteries.
- Battery chemicals can cause a rash. If the batteries leak, clean the battery compartment with a cloth. If chemicals touch your skin then wash it immediately.
- Do not mix old and new batteries.
- Do not mix alkaline, standard (carbon-zinc) or rechargeable (NiCd, NiMH, etc.) batteries.
- Do not continue using the remote if it gets warm or hot.
- Call our Support Center immediately on the support website.

Using your cable set-top box or satellite receiver remote as a 'universal' remote

If you prefer to use your Cable Set-top Box or Satellite Receiver Remote as a 'universal' remote, then visit the Support page to view a list of the codes.

Step 4. Power on the TV

Connect your power cord to the TV and plug it into a power outlet. Press power button of the TV or the power button on the remote to turn on the TV. Your TV will display a launch screen showing the Hisense logo.

Step 5. Complete the first-time setup

The first time you turn on your TV, there is a guided setup to make it easy to connect your TV to the Internet and complete the setup of your TV.

Your TV will automatically pair with your new Alexa Voice Remote.

1. If there are issues with the remote pairing, you will be prompted to pair your remote by pressing and holding the **HOME** button. If you continue to have issues, try re-inserting or replacing your batteries.
2. Select your Wi-Fi network from the list of Wi-Fi networks displayed on the screen.

NOTE:

- If your Wi-Fi network is password protected, please have your Wi-Fi network password handy to connect your TV to the Internet. If your network is hidden, select the **Join Other Network**. If required, enter your network password using the on-screen keyboard.

Step 6. Enjoy your TV!

Now that you've completed the first-time setup, your Home screen is your starting point for using your TV. Your Hisense TV provides a variety of entertainment options, so you'll always find something new. Use your TV to watch live channels, access video on demand to watch movies, and much more.

Troubleshooting

If you are having trouble with your TV, first try turning it off and on again. If this does not fix the problem, check the tips in the following table. If your problem is not listed in the following table, then contact us at one of the phone numbers on Page before.

Issues	Possible solutions
No sound or picture	<ul style="list-style-type: none"> • Check if the power cord is plugged into a powered AC outlet. • Press the Power button on the remote control to activate the unit from 'Standby' mode. • Check to see if the LED light is on or not. If it is, then the TV is receiving power.
I have connected an external source to my TV and I get no picture and/or sound.	<ul style="list-style-type: none"> • Check for the correct output connection on the external source and for the correct input connection on the TV. • Make sure you have made the correct selection for the input mode for the incoming signal.
When I turn on my TV, there is a delay for a few seconds before the picture appears. Is this normal?	<ul style="list-style-type: none"> • Yes, this is normal. The TV is initializing and searching for previous setting information.
The picture is normal but there is no sound	<ul style="list-style-type: none"> • Check the volume settings. • Check if 'Mute' mode is set to On.
Sound but no picture or black and white picture	<ul style="list-style-type: none"> • If the picture is black and white, unplug the TV from the AC outlet and replug it after 60 seconds. • Check that the Color is set to 50 or higher. • Try different TV channels.
The sound and/or picture is distorted or appears wavy	<ul style="list-style-type: none"> • An electric appliance may be affecting the TV. Turn off any appliances that are nearby and move it farther away from the TV. • Insert the power plug of the TV set into another power outlet.
The sound and picture is blurry or cuts out	<ul style="list-style-type: none"> • If using an external antenna, check the direction, position and connection of the antenna. • Adjust the direction of your antenna or reset or fine tune the channel.
A horizontal or vertical stripe appears on the picture and/or the picture is shaking	<ul style="list-style-type: none"> • Check if there is an appliance or electric tool nearby that is causing interference.
The plastic cabinet makes a "clicking" type of sound	<ul style="list-style-type: none"> • The 'click' sound can occur when the temperature of the television changes. This change causes the television cabinet to expand or contract, which makes the sound. This is normal and the TV is OK.
The remote control does not work	<ul style="list-style-type: none"> • Confirm that TV still has power and is operational. • Change the batteries in the remote control. • Check if the batteries are correctly installed.

Product Specifications

Model Name		55U7SF / 55U7SFD / 55U70SF / 55U75SF / 55U78SF / 55U75SFB / 55U75SFC / 55U7SFM / 55U75SFM
Dimension (W × H × D)	Without Stand	48.3 × 28.1 × 3.0 inches (1 226 × 713 × 77 mm)
	With Stand	48.3 × 30.4 × 11.3 inches (1 226 × 773 × 288 mm)
Weight	Without Stand	33.3 lbs (15.1 kg)
	With Stand	35.7 lbs (16.2 kg)
TV Stand Width(W × D)		15.7 × 11.3 inches (400 × 288 mm)
Active Screen Size (Diagonal)		54.6 inches (138.7 cm)
Screen Resolution		3840 × 2160
Audio Power		2 × 10 W + 20 W + 2 × 5 W
Power consumption		200 W
Power Supply		100-240 V~ 50/60 Hz
Connectivity		Built-in Wireless feature (2x2, three band)
Receiving Channels		VHF: 2 - 13, UHF: 14 - 69, CATV: 1 - 125 Digital Terrestrial Broadcast (8VSB): 2 - 69 Digital cable (64/256 QAM): 1 - 135 Next-Gen TV (QPSK-4096 QAM): 2-36
Wireless LAN Module specifications	Frequency Range	2.4-2.4835 GHz 5.15-5.85 GHz 5.9-7.125 GHz
	Output Power (Max.)	2.4-2.4835 GHz 17 dBm 5.15-5.25 GHz 14 dBm 5.25-5.35 GHz(DFS Band) 14 dBm 5.49-5.71 GHz(DFS/TPC Band) 14 dBm 5.725-5.85 GHz(for Non EU) 14 dBm 5.9-7.125 GHz 14 dBm
	Standards	IEEE 802.11 a/b/g/n/ac/ax
Bluetooth Module specifications	Version/Profiles	Bluetooth 5.3
	Frequency Range	2.4-2.4835 GHz
	Output Power (Max.)	2.4-2.4835 GHz, Class1, 6dBm
	Modulation Type	GFSK, π/4-DQPSK and 8-DPSK
Tuner Type		Frequency synthesized
Receiving System		Analog: NTSC Digital: ATSC 1.0/Next-Gen TV/QAM on cable
Operating Temperature		41 °F - 95 °F (5 °C - 35 °C)
Operating Humidity		20 % to 80 % non-condensing
Storage Temperature		5 °F to 113 °F (-15 °C to 45 °C)
Storage Humidity		10 % to 70 %, non-condensing

Disclaimer: All products, product specifications, and data are subject to change without notice to improve reliability, function, design or otherwise.

Certification and compliance

NOTE: The following warnings only apply to products with such certification.

This device complies with Part 15 of the FCC Rules. Operation is subject to the following two conditions: (1) This device may not cause harmful interference, and (2) This device must accept any interference received, including interference that may cause undesired operation.

Note: This equipment has been tested and found to comply with the limits for a Class B digital device, pursuant to Part 15 of the FCC Rules. These limits are designed to provide reasonable protection against harmful interference in a residential installation. This equipment generates, uses, and can radiate radio frequency energy and, if not installed and used in accordance with the instructions, may cause harmful interference to radio communications. However, there is no guarantee that interference will not occur in a particular installation. If this equipment does cause harmful interference to radio or television reception, which can be determined by turning the equipment off and on, the user is encouraged to try to correct the interference by one or more of the following measures:

- Reorient or relocate the receiving antenna.
- Increase the separation between the equipment and receiver.
- Connect the equipment into an outlet on a circuit different from that to which the receiver is connected.
- Consult the dealer or an experienced radio/TV technician for help.

The manufacturer is not responsible for any radio or TV interference caused by unauthorized modifications to this equipment. Such modifications could void the user's authority to operate the equipment.

This equipment complies with FCC radiation exposure limits set forth for an uncontrolled environment. This equipment should be installed and operated with minimum distance of [20] cm between the radiator and your body. This transmitter must not be co-located or operating in conjunction with any other antenna or transmitter.

This device contains licence-exempt transmitter(s)/receiver(s) that comply with Innovation, Science and Economic Development Canada's licence-exempt RSS(s). Operation is subject to the following two conditions:

- (1) This device may not cause interference.
- (2) This device must accept any interference, including interference that may cause undesired operation of the device.

This equipment complies with radio frequency exposure limits set forth by the Innovation, Science and Economic Development Canada for an uncontrolled environment. This equipment should be installed and operated with a minimum distance of 20 cm between the device and the user or bystanders.

This device must not be co-located or operating in conjunction with any other antenna or transmitter.

Declaration of conformity

Trade Name: Hisense

Model: 55U7SF / 55U7SFD / 55U70SF / 55U75SF / 55U78SF / 55U75SFB / 55U75SFC / 55U75FM / 55U75FSM

Responsible Party: Hisense USA Corporation

Service Address: 105 Satellite BLVD Suite I, Suwanee, GA 30024

Service Phone Number: 1-888-935-8880



Dolby, Dolby Vision, Dolby Atmos, and the double-D symbol are registered trademarks of Dolby Laboratories Licensing Corporation. Dolby Vision IQ is a trademark of Dolby Laboratories Licensing Corporation. Manufactured under license from Dolby Laboratories. Confidential unpublished works. Copyright © 2012-2024 Dolby Laboratories. All rights reserved.



The terms HDMI, HDMI High-Definition Multimedia Interface, HDMI Trade dress and the HDMI Logos are trademarks or registered trademarks of HDMI Licensing Administrator, Inc.



Manufactured under license from IMAX Corporation. IMAX® is a registered trademark of IMAX Corporation in the United States and/or other countries. For DTS patents, see <http://patents.dts.com>. Manufactured under license from DTS Licensing Limited. DTS and the DTS logo are registered trademarks or trademarks of DTS, Inc. in the United States and other countries. © 2020 DTS, Inc. ALL RIGHTS RESERVED.



Manufactured under license from DTS, Inc. and/or its affiliates. For patents, see <https://xperi.com/dts-patents/>. DTS, the DTS logo, DTS:X, the DTS:X logo, Virtual:X, and the DTS Virtual:X logo are trademarks or registered trademarks of DTS, Inc. and/or its affiliates in the U.S. and/or other countries. © DTS, Inc. and/or its affiliates. All rights reserved.



Environmental Protection

This mark indicates that this product should not be disposed together with other domestic garbage, to avoid damage to the environment or human health due to the disposal of uncontrolled waste. Recycle it responsibly for promoting the sustainable reuse of material resources. To return your used device, please use the return systems available in your location or contact the vendor where you purchased your product they could take this product for recycling and protection of the environment.

©2025. All rights reserved.

Amazon, Fire, Alexa, and all related marks are trademarks of Amazon.com, Inc. or its affiliates.

This television is a product of Hisense and is not manufactured by Amazon.com or any Amazon affiliate. Certain services and features are subject to change or withdrawal at any time, may not be available in all countries, areas and languages.

THIS PRODUCT IS LICENSED UNDER THE AVC PATENT PORTFOLIO LICENSE FOR THE PERSONAL USE OF A CONSUMER OR OTHER USES IN WHICH IT DOES NOT RECEIVE REMUNERATION TO (i) ENCODE VIDEO IN COMPLIANCE WITH THE AVC STANDARD ("AVC VIDEO") AND/OR (ii) DECODE AVC VIDEO THAT WAS ENCODED BY A CONSUMER ENGAGED IN A PERSONAL ACTIVITY AND/OR WAS OBTAINED FROM A VIDEO PROVIDER LICENSED TO PROVIDE AVC VIDEO. NO LICENSE IS GRANTED OR SHALL BE IMPLIED FOR ANY OTHER USE. ADDITIONAL INFORMATION MAY BE OBTAINED FROM MPEG LA, L.L.C. SEE [HTTP://WWW.MPEGLA.COM](http://www.mpegla.com)